

S.NO	CATALOG NUMBER	D	W
1	BGSSE162630SP	16 [406]	26 [660]
2	BGSSE182630SP	18 [457]	26 [660]
3	BGSSE183030SP	18 [457]	30 [762]
4	BGSSE186030SP	18 [457]	60 [1524]
5	BGSSE223030SP	22 [559]	30 [762]

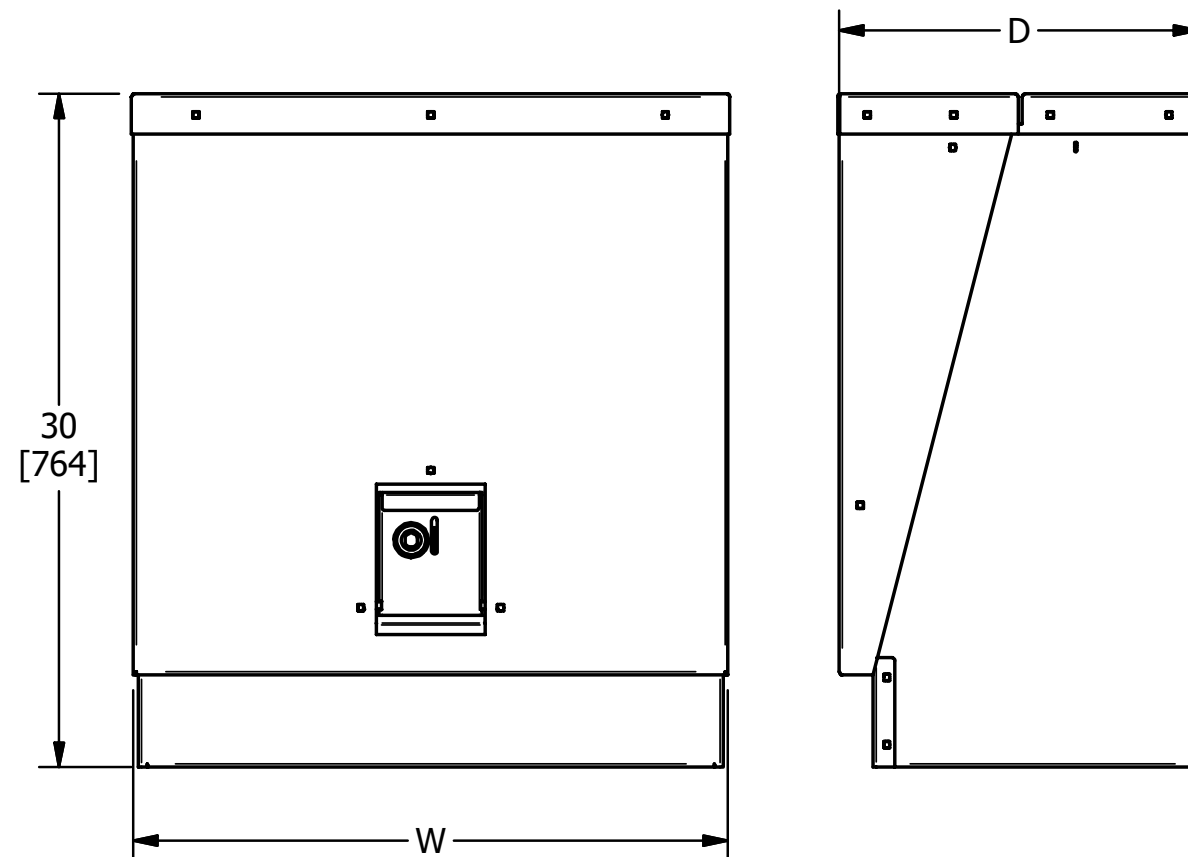
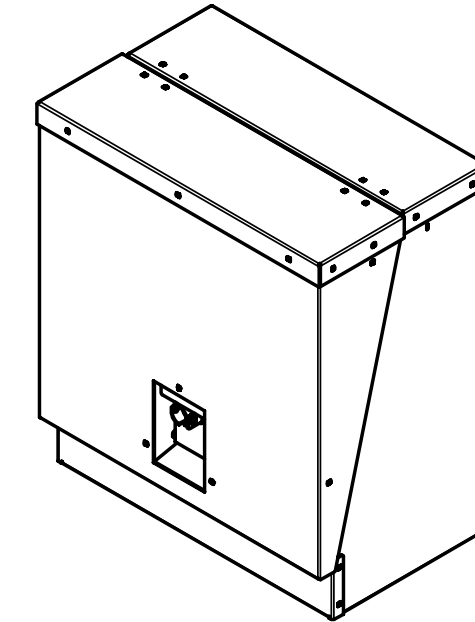

NOTES:

- HEAVY-DUTY CHANNELIZED CONSTRUCTION
- STANDARD CABINET IS FABRICATED FROM 14 GAUGE GALVANEEL STEEL
- ALSO AVAILABLE IN STAINLESS STEEL OR ALUMINUM (CONTACT REP)
- HEAVY DUTY WIND LOCKS ARE STANDARD ON ALL MODELS
- CUSTOM SIZES AND SPECIAL JUNCTION MOUNTING BRACKETS AVAILABLE
- STAINLESS STEEL HINGE BARRELS, PINS, PADLOCK HASP, AND EXTERIOR HARDWARE
- GROUND NUT PROVISION FOR EACH PHASE. UNITS SHIPPED COMPLETELY ASSEMBLED (EXCEPT JUNCTIONS)
- OVEN CURED GREEN POWDER COAT POLYESTER FINISH EXCEEDS ANSI STANDARD C57.12.28
- STANDARD PAINT COLOR: MUNSELL DARK GREEN. OTHER COLORS AVAILABLE
- USABLE JUNCTIONS-4 WAY
- USE FOR THREE PHASE

					TO ORDER CMC PRODUCTS	DRAWN BY: <b>TS</b>	NAME OF PART: SECTIONALIZING ENCLOSURES SINGLE AND THREE PHASE 15, 25 & 35KV	CAT. NO.: SEE TABLE
					UNITED STATES 1-513-860-4455	04-20-20		
					CANADA 1-800-361-6975	CHECKED BY:	DWG NO: UB22700202-S (CHARTED)	A
					MEXICO 011-52-722-265-4400			
<b>A</b>	NEW DRAWING CREATED		04-20-20	TS	FOR PRODUCT INFO www.cmcugs.com	DRAWING NOT TO SCALE		SHEET NO: 1 OF 1

